

XZA系列安装联结尺寸:

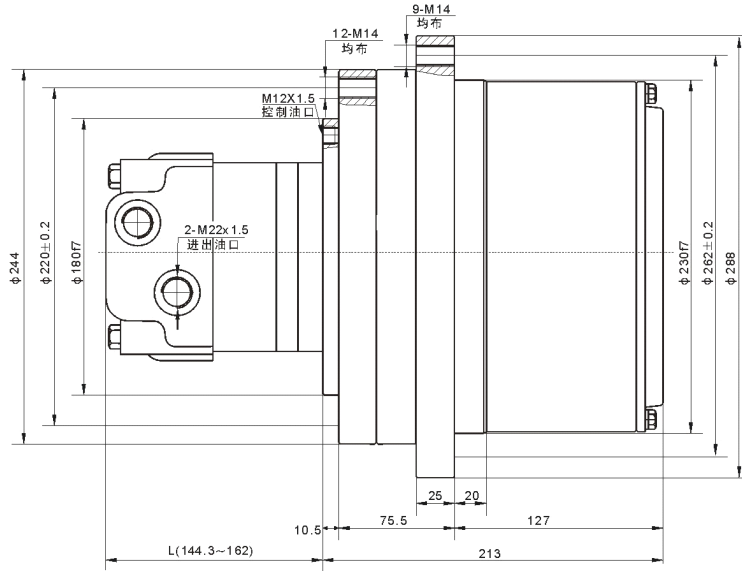

性能参数:

型号 TYPE	额定扭矩 N.m	转速范围 r/min	最高压力 MPa	配用马达 Hydraulic motor	减速比 Ratio	制动器 Brake		自重 KG
						静制动扭矩 N.m	最小开启压力 MPa	
XZA-3100	3150	1-64	21	2W-195	6	2500	2.0	70
XZA-2600	2690	1-79	21	2W-160	6	2500	2.0	
XZA-2200	2280	1-96	21	2W-130	6	2500	2.0	
XZA-1700	1740	1-123	21	2W-100	6	2500	2.0	
XZA-1300	1390	1-133	21	2W-80	6	2500	2.0	